

INDUSTRIAL TOW TRACTOR



HAULING MACHINE

- ▶ 15,000 lb. Capacity on Flat Surfaces
- ▶ 24V Electrical System
- ▶ AC Drive Motor
- ▶ Power Steering
- ▶ Cold Storage Conditioning



TT1-HC150

IN IT FOR **THE LONG HAUL**

When it comes to heavy-duty towing, Toyota's Industrial Tow Tractor is here to get the job done. Designed with a towing capacity of 15,000 lbs. on flat surfaces, this piece of equipment is capable of towing even the heaviest of loads with ease. Its power steering capability allows you to transport items from point A to point B seamlessly, so you never have to worry about getting the job done. The Toyota Industrial Tow Tractor is the versatile, efficient tugger you need in your fleet.

INDUSTRIAL TOW TRACTOR **ADVANTAGES**

- ▶ **POWER STEERING** decreases the amount of effort required to steer, increases operator comfort and efficiency
- ▶ **COLD STORAGE CONDITIONING** protects components from condensation and cold temperatures
- ▶ **OPERATOR COMPARTMENT SENSOR** encourages the operator to stand in the proper position for optimal comfort
- ▶ **LARGE MAGNETIC BATTERY-MOUNTED STORAGE TRAY OPTION** provides storage for operators to place their items
- ▶ **TURTLE SPEED BUTTON** slows the maximum operating speed for improved control and precision

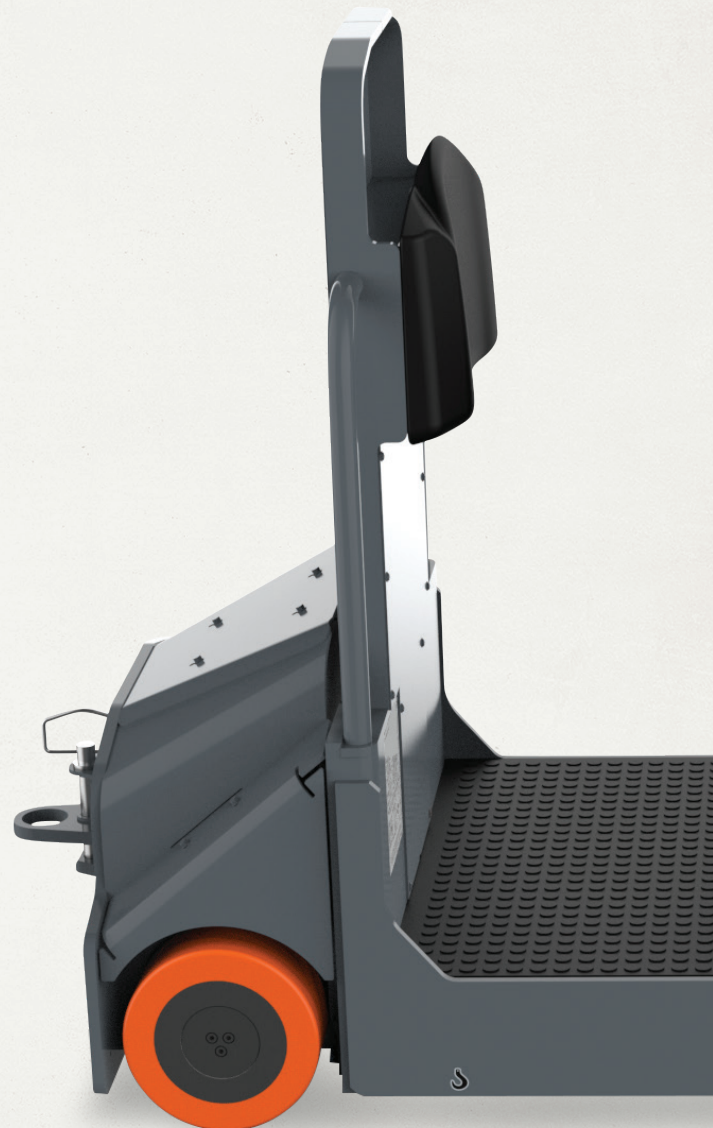

15,000^{LB.}

CAPACITY ON FLAT SURFACES

HEAVY DUTY TOWING

When you need to move products quickly and easily through your facility, Toyota's Industrial Tow Tractor is the right piece of equipment for the job. Equipped with an AC Drive Motor, this tugger provides the power you need to accomplish your daily tasks. Additionally, the Industrial Tow Tractor includes regenerative plugging, which not only reduces energy costs but results in increased efficiency and productivity shift after shift. Programmable performance comes standard to allow customization for a variety of applications.

ERGONOMICALLY PRODUCTIVE

We designed the Toyota Industrial Tow Tractor to not only work with you but for you. This equipment includes a multifunction control handle with ergonomically positioned handgrips, dual thumbwheels, and lift, lower, and horn buttons for simplified operation of all controls with either hand. The Industrial Tow Tractor comes equipped with a cushioned operator backrest and knee pad to provide operator comfort while traveling forward and in reverse. The operator compartment sensor also encourages the operator to stand in the proper position for optimal comfort and performance.



INDUSTRIAL TOW TRACTOR

TOWING CAPACITY
15000 LB. ON FLAT SURFACES

DRAWBAR PULL
1600 LBS.

VOLTAGE
24

INDUSTRIES



Beverage



General
Manufacturing



General
Warehousing



Food
Processing



Retail



Furniture

STANDARD FEATURES

PERFORMANCE

- 24 Volt Electrical System
- AC Drive Motor
- Regenerative Plugging
- Cold Storage Conditioning
- Battery Discharge Indicator with Lift Interrupt
- Hour Meter Indicator
- Electric Disc Brake
- Programmable Performance
- Power Steering
- UL Type "E" Construction

BODY/EXTERIOR DESIGN

- Battery Gate Interlocks
- Electronic Travel Alarm
- Poly Load Wheels
- Rubber Drive Tire
- Battery Compartment
 - 30.68 in. wide
 - 13.7 in. length
 - 31.0 in. height
- Emergency Power Disconnect
- Operator Compartment Sensor

OPERABILITY & ERGONOMICS

- Cushioned Knee Pad
- Cushioned Operator Backrest
- Directional Thumb Wheels
- Power Steer Control Handle with Ergonomically Angled Hand Grips
- Soft-cushioned Floor Mat
- Wrap-Around Hand Guard
- Handle Mounted Rabbit Switch

OPTIONAL EQUIPMENT

BODY

- Single-Tier Accessory Bar
- Operator Cooling Fan
- LED Work Light
- USB Port
- Travel Alarm
- Travel Alarm (forward only)
- Travel Alarm (reverse only)
- Electronic PIN Code Access Pad
- Keyless On/Off Switch
- 10-Amp Power Hook-up, On-Board Terminal
- Static Strap
- Blue Spot Light
- Magnetic, Battery-Mounted Storage Tray
- Large Magnetic, Battery-Mounted Storage Tray
- Dual Stretch Wrap Holders
- Pin and Clevis Tow Hitch
- Greasable Steer Bearing

BATTERY ACCESSORIES

- Battery Compartment Rollers w/ Dual Sidegates
- Battery Connector, Left Side, SB-175, Blue
- Battery Connector, Left Side, SB-175, Yellow
- Battery Connector, SB-175, Red
- Battery Connector, Option Color SB-350, Red
- Battery Connector, SBX-175, Red
- Battery Connector, SBX-175, Gray
- Battery Connector, SBX-350, Red
- Battery Connector, SBX-350, Gray
- Battery Gate Interlock
- Battery Spacers (front to back)
- Toyota LIB Compatibility

TIRES

- Smoothy Drive Tire
- White Non-Marking, Rubber Drive Tire

SPECIAL MODELS

- Special Paint Color
- Bilingual Decals
- Export Preparation Packaging



TRUCK SPECIFICATIONS

MODEL NUMBER

GENERAL DATA			TT1-HC150	
Load Capacity	lb (kg)		7500 (3402) on grades up to 11%	15000(6800) on Flat Surfaces
Power Type			Battery	
Operator Position			Center-Controlled Rider Tow Tractor	
Tire Type	Drive / Caster / Load		Rubber / Polyurethane / Polyurethane	
Wheels	Front / Rear		1 Drive / 2 Rear	
EXTERIOR DIMENSIONS			TT1-HC150	
A	Overall Width	in (mm)	33.25 (845)	
B	Overall Length	in (mm)	75.7 (1923)	
C	Wheelbase	in (mm)	55.7 (1415)	
D	Turning Radius	in (mm)	69.8 (1773)	
E	Power Unit Height	in (mm)	38 (965)	
F	Overall Height	in (mm)	56-61 (1422-1549)	
G	Operator's Platform Height	in (mm)	8.3 (211)	
H	Operator's Platform Depth	in (mm)	21.8 (554)	
I	Distance from Bumper to Center of Drive Tire	in (mm)	13.3 (338)	
J	Bumper Underclearance	in (mm)	3 (381)	
K	Bumper Height	in (mm)	15 (381)	
	Gross Weight Without Battery	lb (kg)	3410 (1547)	
PERFORMANCE DATA			TT1-HC150	
Travel Speed	Full Load	mph (km/h)	6 (9.6)	
	No Load	mph (km/h)	6 (9.6)	
Drawbar Pull	Continuous	lb (kg)	350 (159)	
	Maximum	lb (kg)	1600 (726)	
TIRES			TT1-HC150	
Tires	Number	Front / Rear	1 / 2	
	Size (dia. x width)	Drive (front)	in (mm)	12 x 4.75 (305 x 121)
		Rear	in (mm)	10 x 4 (254 x 101)
POWER SYSTEM			TT1-HC150	
Battery	Voltage / Capacity	V / Ah	24 / 750	
	Connector (Color)		SB-175 (Gray)	
	Connector Cable Location		B	
	Connector Cable Length	in (mm)	18 (457)	
Battery Compartment	Width	in (mm)	13.93 (354)	
	Length	in (mm)	31.68 (806)	
	Height	in (mm)	31 (787)	
Battery Weight	Maximum	lb (kg)	1500 (680)	
	Minimum	lb (kg)	1300 (589)	
Electric Motors	Drive (60 minutes)	hp (kW)	4.4 (3.3)	

EXTERIOR DIMENSIONS

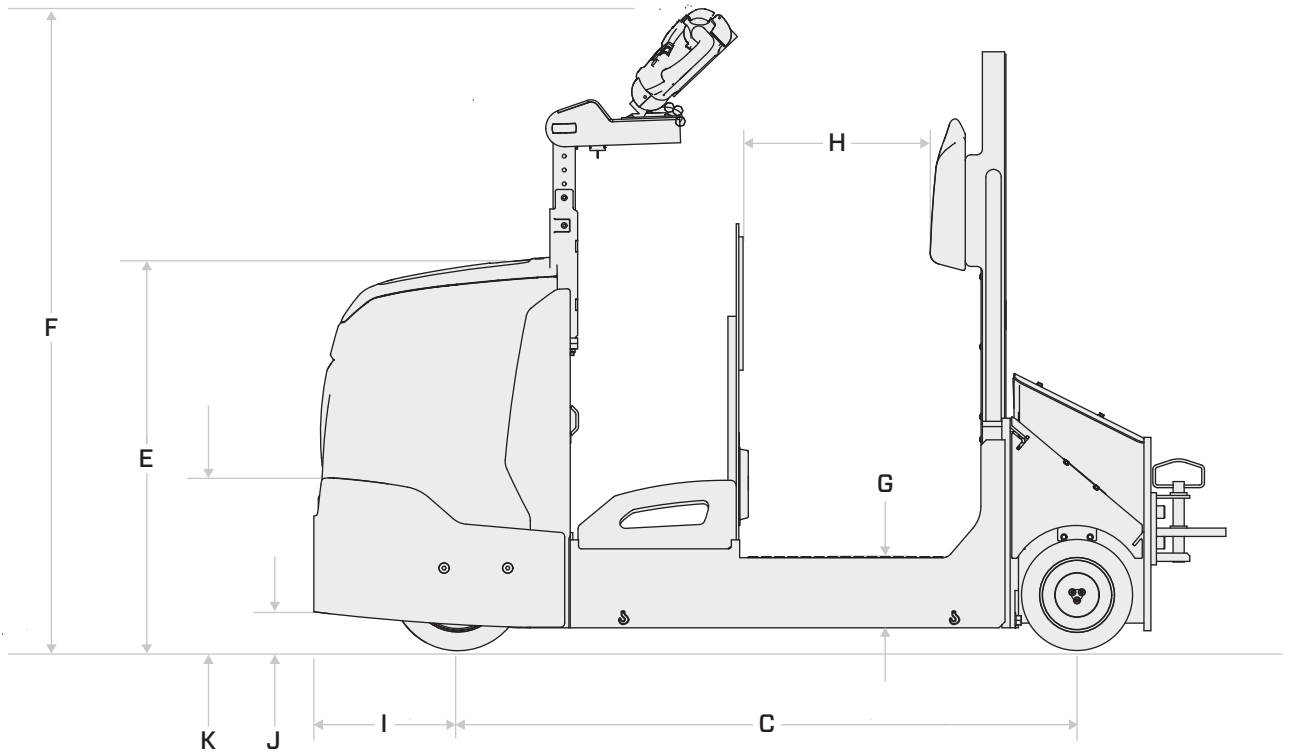
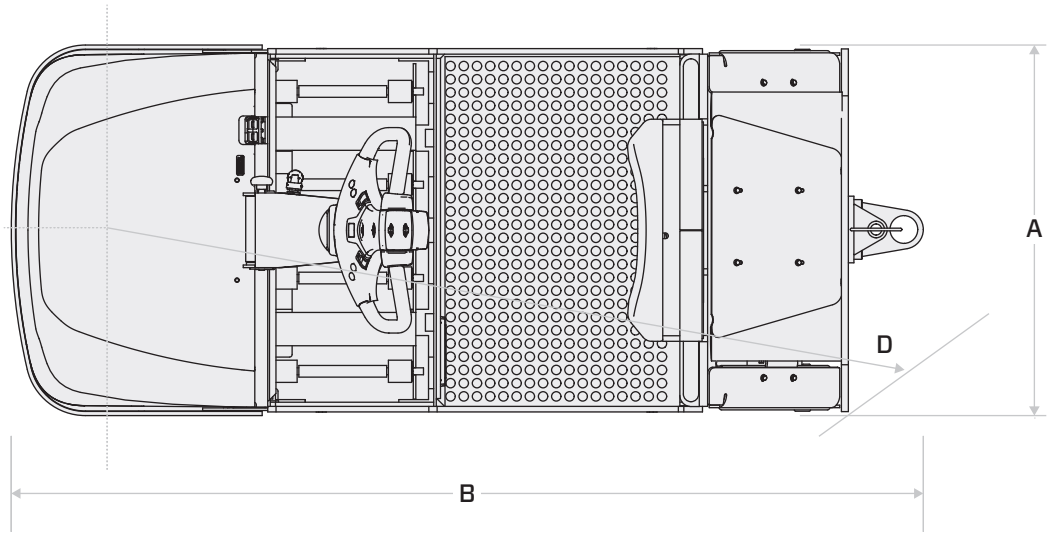



“THE NAME ON MY SHIRT
SAYS TOYOTA,
BUT I WORK
FOR YOU.”

Alan – 360 Technician, Atlas Toyota Material Handling, Chicago, IL



HELP IS ALWAYS HERE WITH TOYOTA 360 SUPPORT.

The industry’s best and most comprehensive dealer network quickly delivers Toyota Certified Technicians to your work site. These specially trained technicians can also help assess your warehouse and facility needs to recommend the right equipment for the job. And with the largest fleet of used and rental material handling products, Toyota 360 keeps your business running at full speed.

ToyotaForklift.com/360-Support



YOUR BUSINESS IS RIDING ON IT.

Some product features described herein are optional. Please consult your dealer for specifications. Details of specifications and equipment are based on information available at time of printing and may change without notice.

