

MID TOW TRACTOR



BIG ON PULL

- ▶ 8800 - 13200 lb. Towing Capacity
- ▶ 8.4 - 11.2 mph Travel Speed Without Load
- ▶ 48-Volt DC Drive System
- ▶ Tight Turning Radius
- ▶ Stand-Up & Sit-Down Models



CBT4-6 | CBTY4

CLASS
3

ELECTRIC PALLET JACKS | STACKERS | TOW TRACTORS

ToyotaForklift.com

STANDS UP TO THE JOB, EVEN IF YOU PREFER SITTING DOWN

THE TOYOTA MID TOW TRACTOR. When you're in it for the long haul, direct or with multiple stops, the Mid Tow Tractor is up to the job. It's available in two configurations: sit-down — perfect for longer runs — and stand-up — ideal for frequent on-and-offs. Either way, you're getting a high-performance truck with great acceleration, productivity-boosting ergonomics and long-term dependability. It's a true all-around player, found everywhere from industry and manufacturing, to health care and hospitals, to distribution, aviation, and more.

48^v

DC DRIVE SYSTEM



CBT6

11.2^{MPH}

CBT6 TRAVEL SPEED
WITHOUT LOAD

13200^{LB.}

CBT6 CAPACITY

MID TOW TRACTOR ADVANTAGES

- ▶ **48-VOLT DC DRIVE SYSTEM** for optimal performance in the toughest applications
- ▶ **GENEROUS 8800 – 13200 LB. TOWING CAPACITY**
- ▶ **TIGHT TURNING RADIUS** advantageous for cramped, busy work environments
- ▶ **TRANSISTOR CONTROL SYSTEM** for smooth acceleration and improved battery efficiency
- ▶ **TRANSVERSE-MOUNTED DRIVE MOTOR** for excellent power efficiency and gradeability
- ▶ **SMALL-DIAMETER STEERING WHEEL**, with a two-stage reduction unit, provides effortless steering
- ▶ **CENTER PIN-MOUNTED FRONT AXLE** for a smoother ride
- ▶ **ERGONOMIC OPERATOR COMPARTMENT** designed with end user comfort and enhanced visibility of meters and gauges in mind
- ▶ **QUICK-RELEASE TOW HITCH** option lets operator release carts without leaving operator compartment, streamlining work operations



TOYOTA

MID TOW TRACTOR

TOWING CAPACITY

8800 - 13200 LBS.

DRAWBAR PULL

880 - 990 LBS.

VOLTAGE

48

INDUSTRIES



Airport



Cold Storage



Food Storage



General Manufacturing



General Warehousing

STANDARD FEATURES

PERFORMANCE

- 48-Volt electrical system
- Transistor Control System
- Transversely mounted drive system
- Transmission with helical gears
- Hour meter indicator
- Battery discharge indicator
- Solid pneumatic tires
- Hydraulic brakes
- On/off key switch

BODY/EXTERIOR DESIGN

- Heavy-gauge steel frame construction
- Heavy-duty front steel panel
- Rear tow hitch (pin & clevis type)
- Rear storage area
- Double-action parking brake²
- Parking brake (foot operated)¹
- Non-skid platform surface¹
- Recessed headlight
- Battery hood assist damper²
- Electronic horn

OPERABILITY & ERGONOMICS

- Operator Presence Sensing System (OPSS)
- Forward/reverse speed control lever¹
- Rear lean point¹
- Adjustable seat (fore-aft)²
- Easy to reach controls and levers
- Small diameter steering wheel²
- Low step height
- Wide operator floorboard
- Center pin dampening device
- Electric shift lever²
- Seat switch²
- Floor switch¹

OPTIONAL EQUIPMENT

- Seat switch with dedicated hour meter²
- Floor switch-operated hour meter¹
- Rear combination lights
- Front combination lights (turn signal)
- Strobe light wiring
- 4-way hazard lights
- Forward and back up chime
- Steering wheel with knob³
- Keyless key switch
- Tilt steering column
- Rearview mirrors (right & left sides)
- Front bumper²
- Quick-release tow hitch²
- Body color (one, two, three or four tone), specify color(s)
- Pencil holder
- Document box
- Clipboard
- Fast charge modification⁵
- Floor mat⁴
- Battery roll-out³
- Battery carrier¹
- Non-marking solid pneumatic tires (front & rear)
- Pneumatic tires (front & rear)

¹ Option not available on CBT4 or CBT6.

² Option not available on CBTY4.

³ Option comes standard on CBTY4.

⁴ Option comes standard on CBT4 & CBT6.

⁵ Fast charge modification includes mounting holes for rear connector brackets & clearance holes for battery & jumper cable. Option not available on CBT6 or CBTY4.

Please contact your local, authorized Toyota Dealer for a complete list of available options.

TRUCK SPECIFICATIONS

MODEL NUMBERS

GENERAL DATA			CBT4	CBT6	CBTY4
Towing Capacity	lb (kg)		8800 (4000)	13200 (6000)	8800 (4000)
Power Type			Battery	Battery	Battery
Operator Position			Seated Rider	Seated Rider	Stand-Up Rider Tow Tractor
Tire Type	Front & Rear		Solid Pneumatic	Solid Pneumatic	Solid Pneumatic
Wheels (x = driven)	Front / Rear		2 / 2x	2 / 2x	2 / 2x
EXTERIOR DIMENSIONS			CBT4	CBT6	CBTY4
A Overall Length	With Tow Hitch	in (mm)	79.5 (2020)	79.5 (2020)	69.1 (1755)
	Without Tow Hitch	in (mm)	74 (1880)	74 (1880)	63.6 (1615)
C Overall Width	in (mm)		38 (965)	38 (965)	38 (965)
D Overall Height	in (mm)		49.2 (1250)	49.2 (1250)	46.7 (1185)
E Outside Turning Radius	in (mm)		69.9 (1775)	69.9 (1775)	63 (1600)
F Wheelbase	in (mm)		53.5 (1360)	53.5 (1360)	44.9 (1140)
G Underclearance	in (mm)		3.15 (80)	3.15 (80)	3 (75)
H Operator's Platform Height	in (mm)		13 (330)	13 (330)	7.9 (200)
I Tread	Front	in (mm)	10.2 (260)	10.2 (260)	10.2 (260)
	Rear	in (mm)	31.7 (805)	31.7 (805)	31.7 (805)
K Tow Hitch Length	in (mm)		5.5 (140)	5.5 (140)	5.5 (140)
L Tow Hitch Height	in (mm)		12 (305)	12 (305)	12 (305)
PERFORMANCE DATA			CBT4	CBT6	CBTY4
Travel Speed	No Load	mph (km/h)	8.4 (13.5)	11.2 (18)	8.4 (13.5)
	With Load	mph (km/h)	5.6 (9) with 4400 lb (2000 kg)	8.1 (13) with 6600 lb (3000 kg)	5.6 (9) with 4400 lb (2000 kg)
Drawbar Pull	3-Minute Rating	lb (kg)	880 (400)	990 (450)	880 (400)
	60-Minute Rating	lb (kg)	220 (100)	330 (150)	220 (100)
Gradeability	No Load	%	36	32	36
	With Load	%			
Reference chart on bottom of page for Gradeability capacities					
TRUCK WEIGHTS			CBT4	CBT6	CBTY4
Total Weight	Without Battery	lb (kg)	1190 (540)	1290 (585)	1380 (625)
	With Battery	lb (kg)	2560 (1160)	2730 (1240)	2240 (1015)
Weight Distribution	Front	lb (kg)	840 (380)	970 (440)	640 (290)
	Rear (drive)	lb (kg)	1720 (780)	1760 (800)	1600 (725)
TIRES			CBT4	CBT6	CBTY4
Tires	Front	in (mm)	3.5 - 5 (90 - 127)	3.5 - 5 (90 - 127)	3.5 - 5 (90 - 127)
	Rear	in (mm)	4.0 - 8 (100 - 200)	4.0 - 8 (100 - 200)	4.0 - 8 (100 - 200)
Brake	Foot		Hydraulic	Hydraulic	Hydraulic
	Hand		Mechanical	Mechanical	Mechanical
POWER SYSTEM			CBT4	CBT6	CBTY4
Battery (6-hour rating)	Maximum Voltage / Capacity	V / Ah	48 / 400	48 / 400	48 / 220
Battery (maximum weight)	Without Rollers	lb (kg)	1390 (630)	1455 (660)	—
	With Rollers	lb (kg)	1235 (560)	1235 (560)	950 (430)
Electric Motor	60-Minute Rating	hp (kW)	3.5 (2.6)	6.6 (4.9)	3.5 (2.6)
Control Type	Power Steering		Transistor Chopper	Transistor Chopper	Transistor Chopper

GRADEABILITY

GRADE	CBT4		CBT6		CBTY4	
	3-MINUTE CAPACITY	60-MINUTE CAPACITY	3-MINUTE CAPACITY	60-MINUTE CAPACITY	3-MINUTE CAPACITY	60-MINUTE CAPACITY
degree	lb (kg)	lb (kg)	lb (kg)	lb (kg)	lb (kg)	lb (kg)
1	7840 (3400)	4180 (1900)	8630 (3800)	6600 (3000)	7840 (3400)	4180 (1900)
2	5940 (2700)	2200 (1000)	6600 (3000)	3960 (1800)	5940 (2700)	2200 (1000)
3	4840 (2200)	1100 (500)	5280 (2400)	2420 (1100)	4840 (2200)	1100 (500)
4	3740 (1700)	440 (200)	4400 (2000)	1320 (600)	3740 (1700)	440 (200)
5	3080 (1400)	—	3520 (1600)	660 (300)	3080 (1400)	—
6	2640 (1200)	—	2860 (1300)	220 (100)	2640 (1200)	—

CBTY EXTERIOR DIMENSIONS

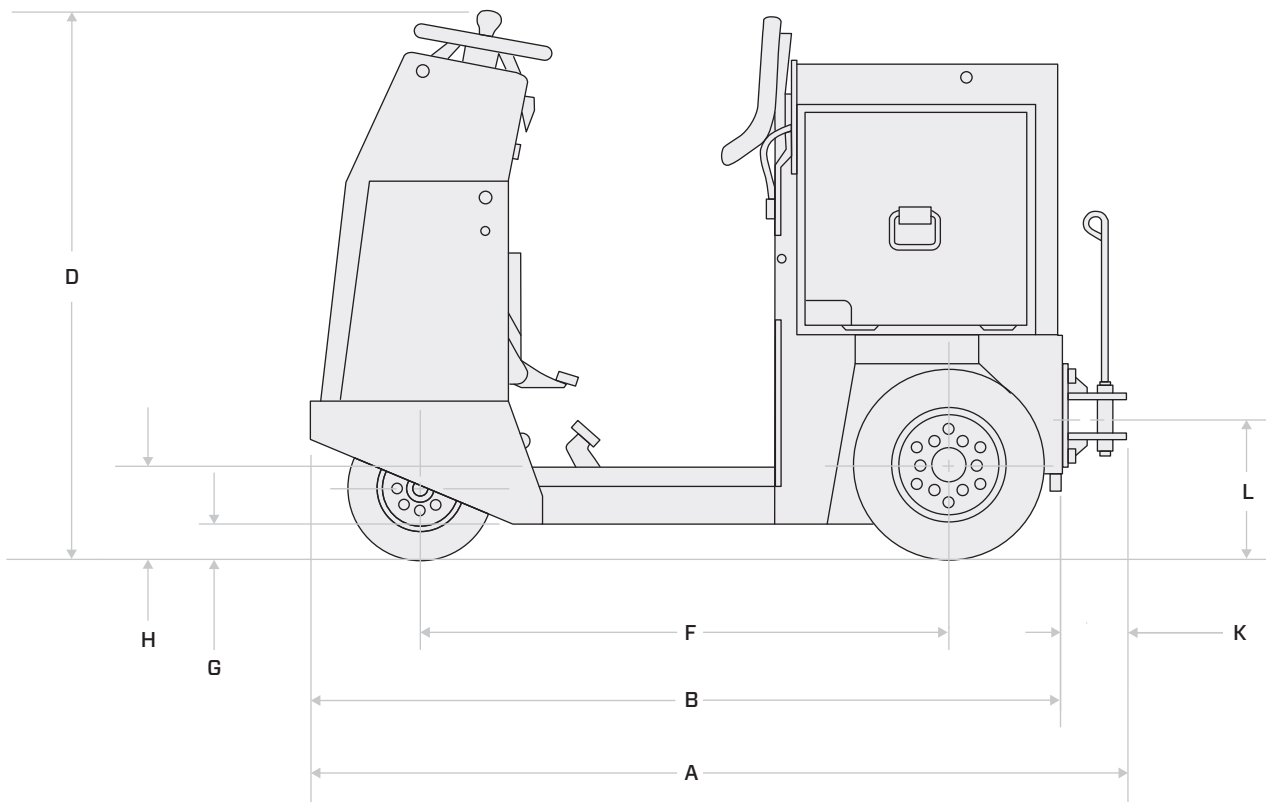
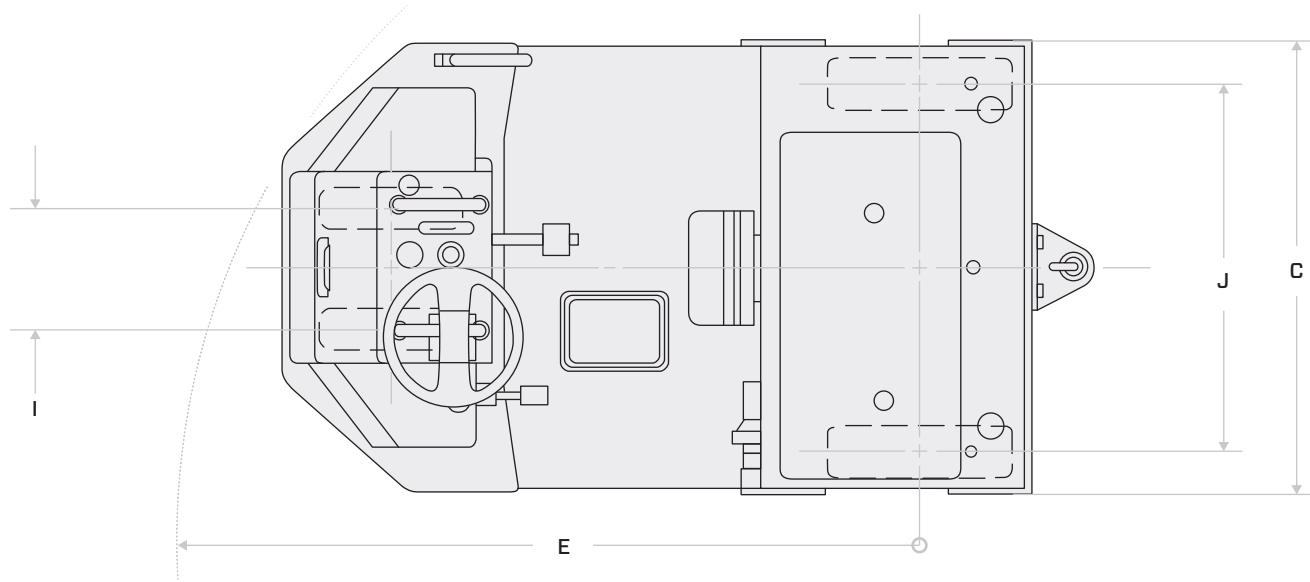

CBT4-6 EXTERIOR DIMENSIONS

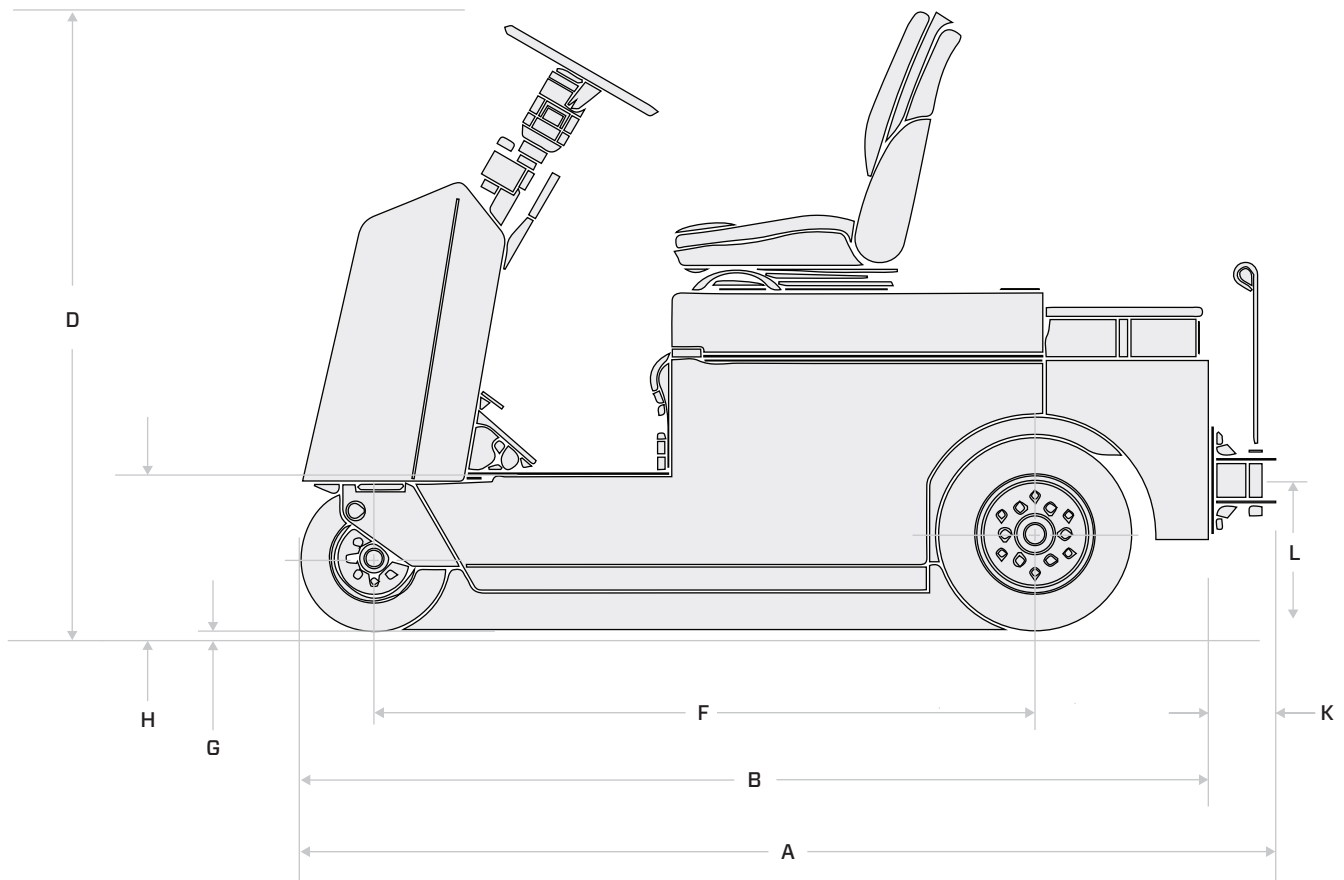
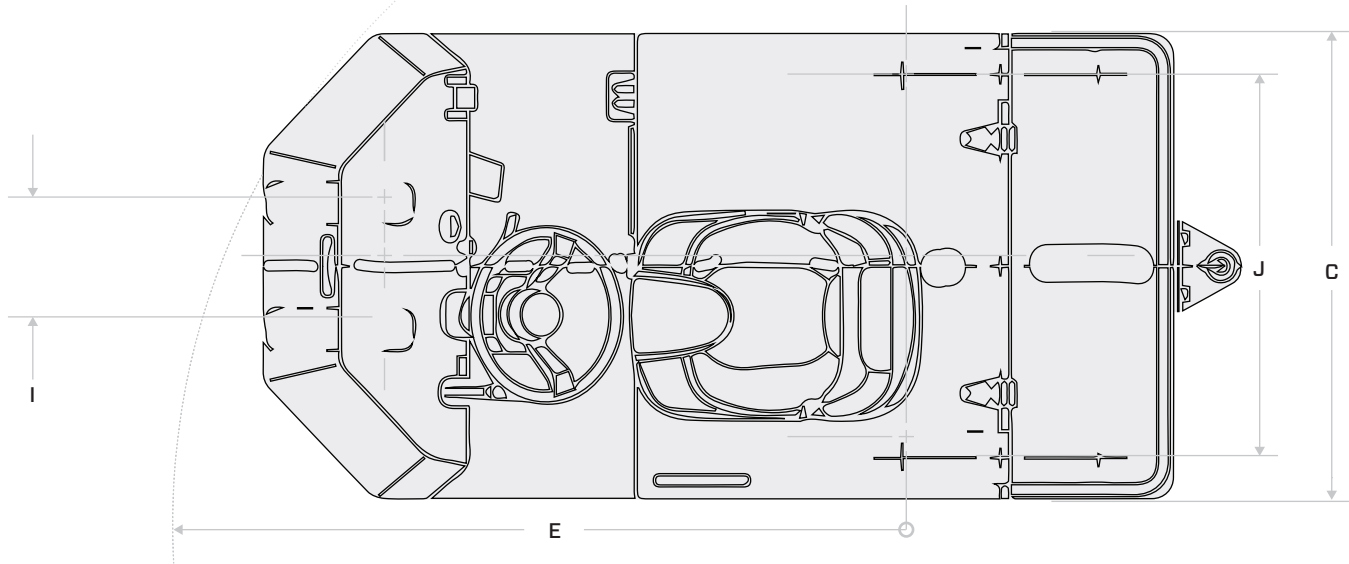



**“THE NAME ON MY SHIRT
SAYS TOYOTA,
BUT I WORK
FOR YOU.”**

Alan – 360 Technician, Atlas Toyota Material Handling, Chicago, IL



HELP IS ALWAYS HERE WITH TOYOTA 360 SUPPORT.

The industry's best and most comprehensive dealer network quickly delivers Toyota Certified Technicians to your work site. These specially trained technicians can also help assess your warehouse and facility needs to recommend the right equipment for the job. And with the largest fleet of used and rental material handling products, Toyota 360 keeps your business running at full speed.

ToyotaForklift.com/360-Support



YOUR BUSINESS IS RIDING ON IT.

Some product features described herein are optional. Please consult your dealer for specifications. Details of specifications and equipment are based on information available at time of printing and may change without notice.



00722CBT4CB

©2019 Toyota Material Handling, Inc.